

Vibrolator® Vibrador Neumatico de Bola

Los Vibradores Neumaticos de Bola proveen vibraciones de alta frecuencia, a un precio economico. La unica parte removable es la bola cromada de acero. No es necesaria la lubricación y tiene una larga duración de vida.



Los mejores usos para estos modelos, son pequeñas tolvas, alimentadores, toboganes, canaletas. El consumo de aire es moderado. Si el requerimiento es de mas de 3 horas de operación por día o requiere lubricación Los Vibradores de Turbina son mejor opción.

Características

Vibrolator Vibradores de Bola

Diseñados para intercambiarlos con la mayoría de marcas en el mercado de Vibradores de Bola, proveen una excelente efectividad a costo bajo de repuestos. Este Vibrador se ha usado por mas de 50 años.

Versatil

Diseñado originalmente para ser usado en la industria de fundición, estas unidades versátiles en el presente están siendo usados para resolver problemas con el manejo de materiales, en otros tipos de industrias.

Dimensiones

MODEL	A	B	C	D	E	F	G	H	J	K	L	M
UCV-6	3 3/4	2 1/16	1 3/16	1 1/8	15/16	3	1/4	1/4	5/8	1/8		
UCV-13	5	2 19/32	1 5/16	1 13/32	1 7/16	4	5/16	3/8	3/4	1/8		
UCV-19	5	3 3/8	1 11/16	1 7/8	1 25/32	4	3/8	3/8	15/16	1/4		
UCV-25	6 1/2	3 7/8	2	2 1/8	2 11/64	5	7/16	1/2	1 1/4	1/4		
UCV-32	6 1/2	4 9/16	2 5/16	2 3/8	2 37/64	5	1/2	1/2	1 9/16	3/8		
UCV-38	7 3/4	5 3/16	2 5/8	2 7/8	2 29/32	6	9/16	5/8	1 7/8	3/8		
UCV-44	8 3/4	5 11/16	2 7/8	3 1/16	3 9/32	7	5/8	5/8	2 3/16	1/2		
BD-10	3 1/8	1 7/8	1 9/32	1 1/4	19/32	1 3/8	1/4	5/16	7/8	1/8		
BD-13	3 3/4	2 3/16	1 3/8	1 5/8	5/8	1 9/16	5/16	3/8	1 1/8	1/4		
BD-16	4 1/8	2 9/16	1 9/16	1 11/16	13/16	1 13/16	3/8	3/8	1 1/4	1/4		
BD-19	4 7/16	2 3/4	1 23/32	1 7/8	13/16	1 15/16	3/8	3/8	1 5/16	1/4		
BD-25	5 7/32	3 1/4	2	2 5/32	1 5/64	2 5/16	1/2	1/2	1 5/8	1/4		
CV-10	3 7/8	2	1 1/4	1 1/4	19/32	3	1/4	5/16	3/4	1/8	1 21/32	1 1/16
CV-19	5 1/8	3 1/8	1 23/32	1 3/4	13/16	4	3/8	3/8	1 1/4	1/4	2 7/16	1 3/4
CV-25	5 1/4	4 1/4	2 1/4	2 1/4	1 1/8	4	1/2	1/2	1 3/4	1/4	3 5/8	2 1/2
CV-35	5 1/4	4 1/4	2 1/4	2 1/4	1 1/8	4	1/2	1/2	1 3/4	1/4	3 5/8	2 1/2
DV-41	6 1/2	4 3/4	2 13/16	2 5/8	1 1/2	5 1/2	1/2	3/8	2 1/8	3/8	3 15/16	1 1/4
DV-51	6 1/2	5 9/32	3 9/32	3 1/8	1 1/2	5 1/2	1/2	3/8	2 1/8	3/8	4 3/16	1 3/4

inches (mm)

Vibrolator® Vibrador Neumatico de Bola

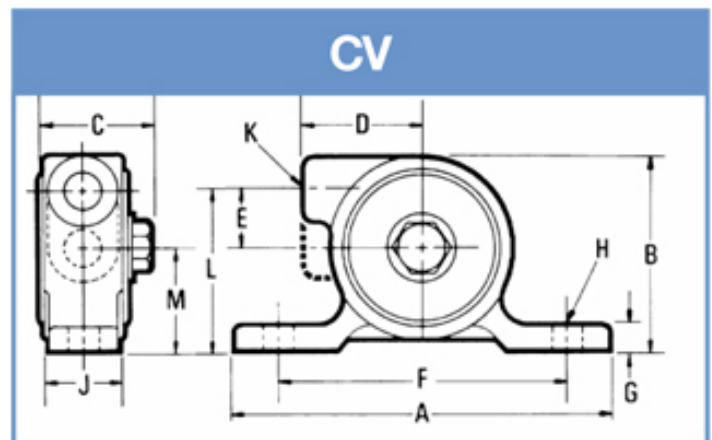
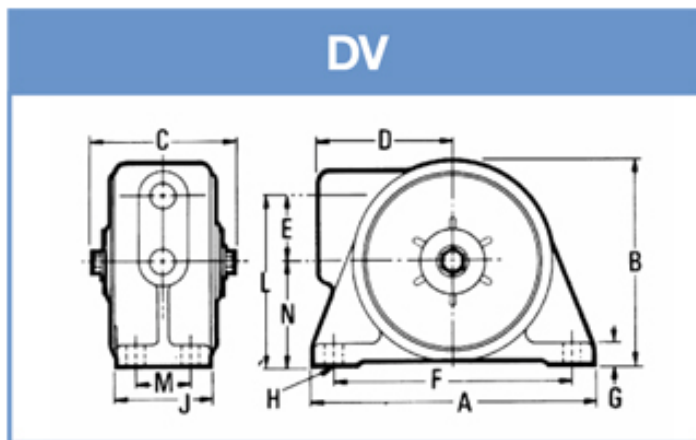
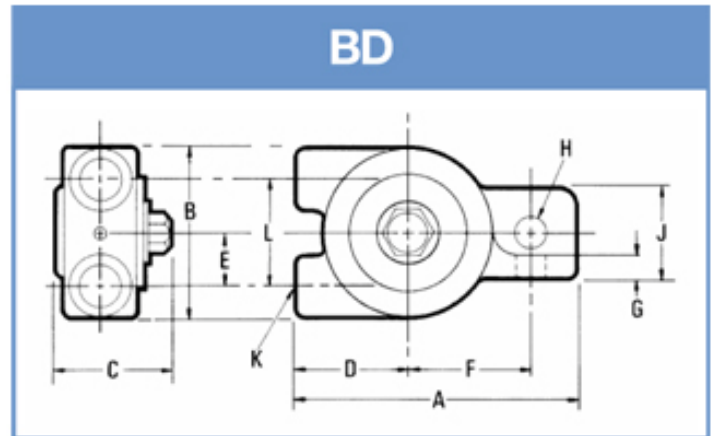
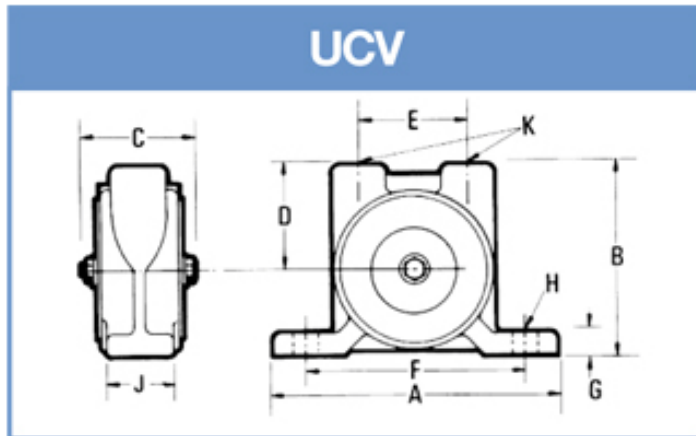

MARTIN® BALL VIBRATORS DIRECTLY INTERCHANGE WITH ALL THESE POPULAR MODELS.

BD-10	E-10	BB-100	BS-10	HB-10	ABL-10
BD-13	E-13	BB-130	N/A	N/A	ABL-13
BD-16	E-16	BB-160	BS-16	N/A	N/A
BD-19	E-19	BB-190	BS-19	HB-19	ABL-19
BD-25	E-25	N/A	BS-25	N/A	N/A
UCV-6	U-6	BV-60	N/A	N/A	N/A
UCV-13	U-13	BV-130	YS-13	HU-13	N/A
UCV-19	U-19	BV-190	US-19	HU-19	N/A
UCV-25	U-25	BV-250	US-25	HU-25	N/A
UCV-32	U-32	BV-320	N/A	N/A	N/A
UCV-38	U-38	BV-380	US-38	N/A	N/A
UCV-44	U-44	N/A	US-44	N/A	N/A
CV-10	VBF-10	V-100	N/A	N/A	ABF-10
CV-19	VBF-19	V-190	CS-19	HC-19	ABF-19
CV-25	VBF-25	V-250	CS-25	HC-25	ABF-25
CV-35	VBF-35	V-320	CS-35	HC-35	ABF-35
DV-41	F-41	N/A	DS-41	HC-41	ABF-41
DV-51	F-51	N/A	DS-51	HC-51	ABF-51

Vibrolator® Vibrador Neumatico de Bola

Rendimiento

MODEL	FREQUENCY			FORCE LBS.			AIR CONSUMPTION (CFM)		
	20 PSI	40 PSI	60 PSI	20 PSI	40 PSI	60 PSI	20 PSI	40 PSI	60 PSI
UCV-6	17,000	22,000	25,000	8	14	18	2	3.5	4.5
UCV-13	12,000	15,000	19,000	33	51	82	2.5	5	7.5
UCV-19	10,500	14,000	16,000	115	205	270	4	7	11
UCV-25	7,500	9,700	11,000	175	275	380	6	10	13
UCV-32	5,100	6,500	7,500	185	285	390	6	11	17
UCV-38	4,200	5,500	6,200	240	410	560	7	14	20
UCV-44	3,900	5,100	6,000	300	530	710	9	15	21
inches (mm)									

MODEL	FREQUENCY			FORCE LBS.			AIR CONSUMPTION (CFM)		
	20 PSI	40 PSI	60 PSI	20 PSI	40 PSI	60 PSI	20 PSI	40 PSI	60 PSI
BD-10*	17,000	21,000	25,000	25	38	54	2	4	6
BD-13*	12,000	15,000	19,000	33	51	82	2.5	5	7.5
BD-16*	11,000	13,000	15,500	69	96	137	3	6	8
BD-19*	10,500	14,000	16,000	115	205	270	4	7	11
BD-25	7,500	9,700	11,000	175	275	380	6	10	13
inches (mm)									

MODEL	FREQUENCY			FORCE LBS.			AIR CONSUMPTION (CFM)		
	20 PSI	40 PSI	60 PSI	20 PSI	40 PSI	60 PSI	20 PSI	40 PSI	60 PSI
CV-10**	17,000	21,000	25,000	25	38	54	2	4	6
CV-19*	10,500	14,000	16,000	115	205	270	4	7	11
CV-25*	7,500	9,700	11,000	175	275	380	6	10	13
CV-35*	6,800	8,800	10,000	315	530	675	6	12	17
DV-41	3,200	4,300	4,900	255	460	600	9	16	24
DV-51	3,100	4,200	4,900	300	540	750	12	19	28
inches (mm)									